

A major purpose of the Technical Information Center is to provide the broadest dissemination possible of information contained in DOE's Research and Development Reports to business, industry, the academic community, and federal, state and local governments.

Although a small portion of this report is not reproducible, it is being made available to expedite the availability of information on the research discussed herein.

RECEIVED BY OSTI DEC 06 1985

Los Alamos National Laboratory is operated by the University of California for the United States Department of Energy under contract W-7408-ENG-38.

LA-UR--85-4019

DE86 003667

TITLE: KRF Lasers as Inertial Fusion Drivers

AUTHOR(S): D. B. Harris, S-4
 R. R. Berggren, P-5
 N. A. Kurnit, CHM-6
 D. D. Lowenthal, R. G. Berger, J. M. Eggleston,
 J. J. Ewing, and M. J. Kushner, Spectra Technology, Inc.

SUBMITTED TO: 11th Symposium on Fusion Engineering
 November 18-28, 1985, Austin, TX

DISCLAIMER

This report was prepared as an account of work sponsored by an agency of the United States Government. Neither the United States Government nor any agency thereof, nor any of their employees, makes any warranty, express or implied, or assumes any legal liability or responsibility for the accuracy, completeness, or usefulness of any information, apparatus, product, or process disclosed, or represents that its use would not infringe privately owned rights. References herein to any specific commercial product, process, or service by trade name, trademark, manufacturer, or otherwise does not necessarily constitute or imply its endorsement, recommendation, or favoring by the United States Government or any agency thereof. The views and opinions of authors expressed herein do not necessarily state or reflect those of the United States Government or any agency thereof.

By acceptance of this article, the publisher recognizes that the U.S. Government retains a non-exclusive, royalty-free license to publish or reproduce the published form of this contribution, or to allow others to do so, for U.S. Government purposes.

The Los Alamos National Laboratory requests that the publisher identify this article as work performed under the auspices of the U.S. Department of Energy.

MASTER
Los Alamos Los Alamos National Laboratory
 Los Alamos, New Mexico 87545

KrF LASERS AS INERTIAL FUSION DRIVERS

D. B. Harris, R. R. Berggren, and N. A. Kurnit
Los Alamos National Laboratory
P. O. Box 1663
Los Alamos, New Mexico 87454
(505) 667-0852

D. D. Lowenthal, R. G. Berger, J. M. Eggleston,
J. J. Ewing, and M. J. Kushner
Spectra Technology, Inc.
2755 Northup Way
Bellevue, Washington 98004
(206) 827-0460

Abstract

A new type of KrF laser system has been proposed that has a significantly higher efficiency than pure angular multiplexed KrF lasers. This system uses electron-beam-sustained discharge lasers to pump a high gain Raman amplifier. The discharge lasers can operate at a higher efficiency than e-beam pumped lasers, and the forward Raman scattering process has both a high gain and high quantum efficiency using the rotational transition. The Raman system cost and performance has been examined and compared to the pure angular multiplexed system. The discharge-Raman system has a higher efficiency (12.3% vs 9.1%) and a higher cost (\$140/joule vs \$100/joule). For an ICF power plant driver, the higher efficiency offsets the higher cost, making the discharge-Raman system appear to be an attractive alternative to the pure angular multiplexed system.

Introduction

The requirements of a commercial applications inertial fusion driver have long been known. The driver must deliver 1-10 MJ with pulse widths of 5-20 ns at a pulse repetition rate of 1-20 Hz (for a 1000 MWe plant), with the optimum operating parameters depending on the cost and efficiency of the driver, and on the target gain.¹ The driver must also be efficient enough so that the product of the target gain and driver efficiency is greater than 10 for pure fusion power. Using standard target gain curves,² the driver efficiency should be at least 5-10%. The wavelength (for lasers) must also be less than 400 nm for efficient target coupling.³ KrF operates at 249 nm. The driver cost must be less than a few hundred dollars per joule for it to be affordable. KrF lasers appear capable of achieving this cost goal.⁴

Only two lasers are thought to be scalable to the required energies with suitable wavelengths: frequency tripled Nd:Glass lasers and pulse compressed KrF lasers. KrF lasers have so far demonstrated higher system efficiencies and, moreover, use a gaseous lasing medium that readily allows repetitive pulsing through forced flow heat removal. A 1978 study⁵ concluded that e-beam-pumped KrF lasers have a maximum potential system efficiency of only 6%. However, recent theoretical⁶ and experimental⁷ work with a new regime of gas mixtures has indicated a possible 50% improvement in the laser intrinsic efficiency over what was thought possible in 1978. New work on expanding-flow e-beam diodes⁸ show improvements in the laser pumping efficiency. These effects combine to make the KrF laser efficiency suitable for a commercial-applications laser fusion driver.

Historically, KrF laser fusion drivers have had many different forms based on the method of pulse compression (KrF lasers operate most efficiently when pumped for hundreds of nanoseconds and thus the pulse must be compressed to the 5-20 ns range required for inertial fusion). In 1980, Mathematical Sciences

Northwest⁹ (now Spectra Technology) and Avco Everett Research Laboratory¹⁰ performed the first conceptual designs for angular multiplexed (optical pulse compression) systems. Recent work with angular multiplexed systems has included improvements in kinetics and e-gun design. It has been found that total laser system efficiencies greater than 9% are possible, and that a 5-MJ single-pulse laser system will cost approximately \$100/joule in 1984 dollars.¹¹ This study used amplifier modules with energies slightly greater than 200 kJ, optical fluences less than 4 J/cm², and was costed as a facility assumed to be built in the 1995-2000 time frame.

Bechtel performed a conceptual design study of a 1.5-MJ, 2-Hz KrF fusion laser system in 1980.¹² This study also used 200-kJ main amplifiers, but used backward Raman scattering for pulse compression instead of angular multiplexing. The backward Raman amplifier approach was used because it was thought important to reduce the alignment system complexity by reducing the total number of beams on target. This is not necessary for three reasons. First, techniques such as aperture combination¹¹ can be used to combine beams in the angular multiplexed approach in order to reduce the number of beams. Second, the number of beams on target is usually set by optical fabrication and cost considerations. The laser energy and the optical damage fluence specifies the total area of optics required. The number of beams is then given by this total area and the optimum size of optical components as determined by the optical manufacturing industry costs and capabilities at the time of construction. This means that the lowest-cost driver might use more beams than needed for target illumination requirements. The third reason that reducing the number of beams is not as important as thought in 1980 is because of the recent advances in alignment system technology.¹¹ The results of the Bechtel study indicate that backward Raman pulse compression is somewhat inefficient (~50%), and that a laser fusion system

based on this process appeared less attractive than the angular multiplexed approach because of the low system efficiency.

Stimulated Brillouin scattering (SBS) was the next system proposed for laser pulse compression for ICF.¹³⁻¹⁹ SBS appeared to promise large compression ratios at high efficiency, flexible pump geometries, beam combination, and beam cleanup. However, a more detailed examination^{10,13} of SBS revealed that the SBS process has no significant advantage over pure angular multiplexing for pulse compression down to the 5-10 ns range (though it can be efficient for generating subnanosecond pulses). Moreover, it produces a non-ideal output Stokes temporal shape that makes pulse shaping appropriate for ICF targets difficult. Furthermore, calculations indicate that SBS transverse window parasitics will be a serious problem for lasers having a linewidth significantly narrow for efficient compression.

Spectra Technology has recently completed a study²⁰ that surveyed all of the possible technologies for KrF laser fusion systems. They found that small (<5kJ) electron-beam-sustained discharge (EBSD) KrF lasers can have a significantly higher efficiency (wall-plug to laser light out) than electron-beam-pumped lasers. These EBSD lasers are also small enough and the required number large enough that factory assembly-line manufacturing and mass production techniques become possible. However, some nonlinear method is required in order to combine these lasers into a tractable number of beams. The Spectra Technology study found that forward-Raman amplifiers²¹ utilizing rotational Raman scattering in H₂ can provide the required beam combination and beam cleanup at high efficiency. If the input Stokes beams are time and angle encoded, then the output Stokes can be separated, demultiplexed, and brought to target by a method very similar to the pure angular multiplexed system.

The purpose of this paper is to examine the cost and performance of the EBSD laser-forward Raman system and compare it to the pure angular multiplexed system. The comparison will be done for a single-shot, multimegajoule system, but the figure-of-merit of the comparison will be their attractiveness as a commercial applications inertial fusion driver.

Discharge Laser-Forward Raman System Description

The architecture and shape of the forward Raman driver system is set by the number of Raman amplifiers needed to deliver megajoule energies to the target and the desire to minimize the cost of optical components and number of beam lines to target. For example, consider a 5-MJ system using 25 final Raman amplifiers; each Raman cell must handle 200 kJ. If the full pulse compression is achieved in the cell and it a 320-ns pump pulse is to be reduced to 8-ns, then there must be 40 Stokes beam lines per Raman cell. Therefore, there are 1000 final beam lines directed to the target. Techniques such as aperture combination can be used to reduce this number if desired. Another determinant of the Raman cell size is the window operating fluence and the path length required for beam separation. The operating fluence sets the minimum Raman cell window size; using a fluence (for the long pump pulses) of 6 J/cm^2 , the window size becomes $\sim 2\text{-m}$ square for a 200 kJ Raman cell. A window this large is beyond the capabilities of current coating machines; thus segmented windows with elements in the 50-100 cm range will be employed. The use of smaller window elements results in reduced window cost, but requires a "grid work" support structure; this subject will be further examined later in this section.

The second determinant of Raman cell size is the required path length to separation. This is the distance required to fully separate the N Stokes beams

that multiplex the Raman amplifier. This distance is fixed by the maximum off-axis field angle that is acceptable in terms of optical aberrations, and the maximum acceptance angle for the forward Raman process. A two-dimensional forward Raman amplifier extraction code was written in order to investigate the Raman processes constraints. This code included the forward Raman gain as a function of angle between the Stokes and pump beams, allowed converging or diverging beams, accounted for imperfect Stokes-pump beam overlap, and included beam reflection from the back mirror (for double-pass Raman cell designs). The results from this code verified that the Raman processes, and associated geometrical effects, are not the limiting processes in terms of beam path lengths to separation when conversion efficiency of over ~90% was achieved. Instead, optical aberration (specifically astigmatism) set the final path length to separation in terms of deliverable beam quality at the target. The result implies that Raman cell f/numbers (ratio of separation path length to Raman aperture size) must be ~25-30; consequently, apertures of 2-3 meters require path lengths of order 50-100 meters.

Raman Amplifier Configuration

There are many possible configurations for the forward Raman amplifier. Two examples include: (1) straight through system where the pump and Stokes enter a front window and then the amplified Stokes exits a back window, and (2) a folded system where the pump and Stokes enter a front window, are reflected from a back mirror, and the amplified Stokes then exits back out through the front window. These two arrangements are illustrated in Fig. 1. Both of these designs have the same volume of window material, but different size apertures. The straight-through system "sees" the pump fluence at the front window and the amplified Stokes at the back window. The folded system "sees" both the pump and amplified Stokes at the front window. As a result, the window area is larger

for the folded system by a factor of two and the system includes a large back mirror (which can also be segmented). One might conclude that the straight-through arrangement would be the most cost effective because the large mirror is removed and the window area is the same. However, one of the windows for the straight-through arrangement is actually a lens, and the added cost for figuring the surfaces partially offsets the mirror cost of the folded arrangement. Further, the straight-through geometry has slightly longer overall size when path lengths to separation are included. These tradeoffs have not been fully completed; but for the present reference design, the folded geometry has been tentatively chosen. The basic arrangement for a 200 kJ subsystem is presented in Fig. 2.

Electron-Beam Sustained Discharge Lasers

KrF E-Beam Sustained Discharge (EBS) lasers are viable alternate drivers to purely E-Beam Pumped (EBP) lasers. Extensive modeling studies have been performed to evaluate EBS lasers as fusion drivers. Those studies have shown that under certain conditions, EBS lasers can be significantly more efficient than EBP lasers. This increase in efficiency results, in part, from the fact that the upper laser level is formed dominantly by excitation transfer between neutral species in EBS lasers, as opposed to being formed dominantly by ion-ion neutralization in EBP lasers. The neutral channel is energetically more efficient than is the ion channel. In addition, the wall-plug efficiency at which power can be deposited in the gas is higher for discharges than for e-beams. Electrical circuits for discharges typically have fewer stages of power conditioning, therefore having a higher overall charging and transfer efficiency. There are also significant losses associated with penetration of the e-beam through mechanical structures. Table I shows the pulsed-power requirements for

EBSD and EPB lasers; the mentioned e-beam energy losses do not represent a large fraction of the total EBSD power requirements.

Although EBSD lasers are intrinsically more efficient than are EPB lasers, the laser extraction efficiency is reduced by higher absorption losses resulting from the larger fraction of the halogen donor (F_2) which is required to insure discharge stability. The end result is that the wall plug efficiency of EBSD lasers is calculated to be 14-15% whereas the wall plug efficiency of EPB lasers is 9-10%. It is this projected increase in overall efficiency of EBSD lasers that has motivated us to consider them as fusion drivers.

The projected aperture size (30-35 cm) of the EBSD lasers is smaller than that of EPB lasers (1-3 m), and the energy density is also lower. The result is that the laser energy delivered by a single EBSD laser will be approximately 2.5 kJ, thereby requiring many more EBSD laser modules (on the order of a few thousand) for a fusion power plant than the 10-40 modules required for EPB laser systems. The large number of EBSD lasers is not necessarily a disadvantage since the 320-400 ns output pulse of the smaller laser can be directly imaged onto the forward Raman amplifier, thereby eliminating the need to multiplex, or otherwise condition, the output of the primary laser amplifier before Raman pulse compression occurs. The total number of optical beam lines and optical elements required for a system using the more numerous EBSD lasers therefore differs little from one using fewer, but larger, EPB lasers. Also, there are certain manufacturing mass production and reliability advantages to using EBSD lasers.

Individual EBSD lasers can be packaged quite compactly, thereby maintaining a relatively high average planar energy density. A conceptual design for an EBSD laser module is shown in Fig. 3. The basic building block of the module

consists of a pair of EBSD lasers whose e-beams are commonly housed in the center section. The pulse forming lines (PFL's) for the discharges are folded and stretched longitudinally parallel to the optical axis. The transverse dimension of the PFL's for both the discharges and the e-beams do not exceed that of the laser, thereby allowing the basic laser modules to be stacked vertically. The typical size of the basic laser module containing two lasers is 2.7m x 1.0m x 7m. A 200-kJ array of EBSD laser modules will therefore require an area of approximately 200 m² if stacked four high.

The aperture size of the EBSD lasers could be increased to order 50 cm, thereby reducing the number of required lasers by approximately half and making EBSD lasers appear even more attractive. There are certain system tradeoffs and technical issues that must be considered in scaling the apertures of the EBSD lasers. The technical issues center primarily on the necessity to maintain highly uniform e-beams over the entire aperture, a requirement for discharge stability. By increasing the aperture size of the EBSD lasers, the inductance of the laser head is increased, thereby decreasing the rate of current rise and lengthening the laser pulse. This lengthening of the laser pulse has implications on the degree of multiplexing required before the Raman cells.

EBSD Laser-Forward Raman System Cost and Performance

A reference system has been selected for analysis and comparison with the angular multiplexed case. This system is costed using technology appropriate for the 1995-2000 timeframe. The system generates 5 MJ of laser light from 25 200-kJ Raman amplifiers, and illuminates targets with 8-ns pulses. The two-pass Raman amplifiers have a gain of 400, and are used with the Raman window operating at 6 J/cm² for 320 ns. The demultiplexing and target chamber optical fluence is 4 J/cm². The Raman cell is approximately a 2-meter cube, with the

window and mirror made up of 16 square segments. It is filled with H_2 at 3 atmospheres. The 98 2.5 kJ discharge lasers per Raman cell are 1.5 meters long with a 30 x 35 cm cross section. They are triple-passed with a gain of 100.

The efficiency of this system is equal to the product of four efficiencies; the discharge laser efficiency (15%), transport efficiency from the pump into the Raman cell (98%), the Raman cell efficiency (90%), and the transport efficiency from the Raman cell to the target (93%). The total laser system efficiency is 12.3%.

The cost of this laser system is \$140/joule or 700 M\$ with the cost breakdown shown in Fig. 4. Note that over 25% of the total system cost is for the discharge lasers, 15% of the cost is from optics, and 18% is the cost of beam enclosures. The cost of this system will be compared with the cost of the angular multiplexed system (Fig. 5) in the next section.

Comparison of the Two Systems

The EBCD laser-forward Raman system and the pure angular multiplexed system show similarities and differences. While both systems use 200-kJ final amplifiers, the Raman system is pumped for 320 ns which allows fewer beams to be used for demultiplexing than the 400-ns e-beam pumped amplifiers. The large final Raman amplifiers also have the advantage of using segmented windows. As described before, the Raman cell can be operated around the window support structure so it causes no loss in efficiency. The large e-beam pumped amplifiers have to rely on large monolithic edge-fused windows to eliminate obscuration. Since these windows are large and thick, they contribute significantly to the optics cost for the pure angular multiplexed system. The Raman cell windows contribute a much smaller fraction to the cost of optics.

Another advantage the Raman system has is the ability to use lower quality optics for the pump beam (upstream of the Raman cell). This also helps reduce the total optics cost.

As expected, the large number of discharge lasers makes up a larger fraction of the total cost than do the large e-beam lasers. The large number of amplifiers opens up the possibility of assembly-line construction which can significantly reduce the cost. Finally, system integration costs are expected to be higher for the Raman system due to the larger number of components. The other elements of the two laser systems are comparable in cost.

The cost and efficiency of the Raman system are \$140/joule and 12.3%, respectively, while for the pure angular multiplexed system they are \$100/joule and 9.1%. For an ICF electric power plant, the higher driver efficiency and corresponding lower recirculating power fraction results in a cost savings for the balance of plant that more than offsets the additional driver cost. Thus, from this preliminary analysis of the Raman system, it appears to be an attractive alternative as a driver for an ICF electric power plant.

Summary

A recent study of many different types of KrF lasers has concluded that electron-beam-sustained discharge laser pumping of forward Raman amplifiers using the rotational process appears to have the highest laser system efficiency. This system offers other advantages over the pure angular multiplexed system. The beam cleanup in the Raman cell relaxes the requirements in the discharge laser and allows the use of lower-cost optics. The system is also very high gain, which allows a very simple, low-energy front end.

Though the cost of the Raman system is expected to be higher than the pure multiplexed system, the higher system efficiency appears to make it an attractive ICF driver. Some potential disadvantages of the Raman system is the

"diffuse" nature of the pump, and the large H₂ cells. The cost of the laser hall may be an additional cost burden that has yet to be calculated, and the Raman cells may present a fire/explosion safety hazard. This will be examined in further studies.

References

1. J. H. Pendergrass, "Optimum Driver Pulse Energy/Repetition Rate Combinations for Inertial Fusion Commercial Applications," Fusion Technology 7, July, 1985.
2. R. O. Bangerter, J. W-K. Mark, and D. J. Meeker, "Target Gain for Ion Driver Inertial Fusion," Los Alamos National Laboratory report LA-OR-81-2989 (1981).
3. K. A. Brueckner and R. S. Janda, "Wavelength Dependence of Laser Coupling to Pellet Implosions," Nuc. Fusion, 17, 305 (1977).
4. D. B. Harris and J. H. Pendergrass, "KrF Laser Cost/Performance Model for ICF Commercial Applications," Fusion Technology, 8, 1220 (1985).
5. W. F. Krupke, "Advanced Lasers for Fusion Applications," Proc. Int. Conf Lasers 1978, San Diego, CA, August, 1978, p. 24 (1978).
6. F. Kannari, A. Suda, M. Obara, and T. Fujioka, "Theoretical Evaluation of Electron-Beam-Excited KrF Lasers Using Argon-Free Mixtures of One Atmosphere," Appl. Phys. Lett., 45, 305 (1984).
7. E. T. Salesky and W. D. Kimura, a) post deadline paper at XIII Conf. of Quantum Electronics, b) paper submitted to IEEE J. Quantum Electron.
8. "Conceptual Design Review for the Polaris Power Amplifier Module," presented by Avco Everett Research Laboratory at Los Alamos National Laboratory, November 15-16, 1984.
9. "Conceptual Design of a KrF Scaling Module," MSNW Final Report, DOE/DP/40104 (1980).

10. J. H. Parks, "Conceptual Design for an Angularly Multiplexed Rare Gas Halide Laser Fusion Driver," AERL Final Report, DOE/DP/40113-1 (1980).
11. KrF Laser System for Inertial Confinement Fusion, Los Alamos Status Report, Edited by R. Jensen and D. Hyer, to be published.
12. J. Caird et. al., "Conceptual Design of a 1.5-MJ, 2-Hz KrF Fusion Laser System," Lawrence Livermore National Laboratory Report UCRL-53077 (1980).
13. M. J. Damzen and H. Hutchinson, "Laser Pulse Compression by Stimulated Brillouin Scattering in Tapered Waveguides," IEEE J. Quantum Electron., 19, 7, (1983).
14. I. V. Tomov, R. Fedosejevs, and D. C. D. McKen, "High-Efficiency Stimulated Brillouin Scattering of KrF Laser Radiation in SF," Optics Lett., 9, 405 (1984).
15. M. Slatkine, I. J. Bigio, N. A. Kurnit, and D. E. Watkins, "Pulse Compression of Excimer Radiation by Backward-Stimulated Brillouin Scattering in Gaseous Media," Thirteenth International Quantum Electronics Conference, Anaheim, California 18-21 June 1984.
16. V. A. Eroshenko et. al., "Numerical Investigation of the Possible Use of Stimulated Brillouin Scattering in Laser Fusion Facilities," Sov. J. Quantum Electron, 10, 1481 (1981).
17. Yu. V. Dolgoplov et. al., "Experimental Investigation of the Feasibility of Application of the Wavefront Reversal Phenomenon in Stimulated Mandel'shtam-Brillouin Scattering," Sov. Phys. JETP, 49, 458 (1979).
18. V. A. Gorbunov et. al., "Time Compression of Pulses in the Course of Stimulated Brillouin Scattering in Gases," Sov. J. Quantum Electron., 13, 900 (1983).

19. S. B. Kormer, et. al., "Use of Stimulated Mandelstam-Brillouin Scattering for Peaking Pulses and Interstage Decoupling in Laser Fusion Experiments," Sov. Phys. Tech. Phys., 25, 757 (1980).
20. J. J. Ewing et. al., "Nonlinear Techniques for Fusion Lasers," Spectra Technology report, (1985).
21. M. J. Shaw et. al., "High-Power KrF-Laser-Pumped Raman Amplifier," Conf. on Laser and Electro-Optics, Baltimore, Maryland, 21-24 May 1985.

Figure Captions

- Fig. 1. Two possible forward Raman amplifier designs using single-pass and double-pass geometries.
- Fig. 2. The e-beam sustained discharge KrF lasers pump the large Raman amplifier. The input Stokes beams is time and angle encoded so the output Stokes beams can be decoded to deliver short, shaped pulses to the target.
- Fig. 3. A pair of e-beam sustained discharge lasers form the basic building block. These amplifiers can be stacked vertically.
- Fig. 4. Cost breakdown for a 5-MJ discharge-Raman system. The total laser system cost is \$140/joule with a system efficiency of 12.3%.
- Fig. 5. Cost breakdown for a 5-MJ pure angular multiplexed system. The laser system cost and efficiency is \$100/joule and 9.1% (from Ref. 11).

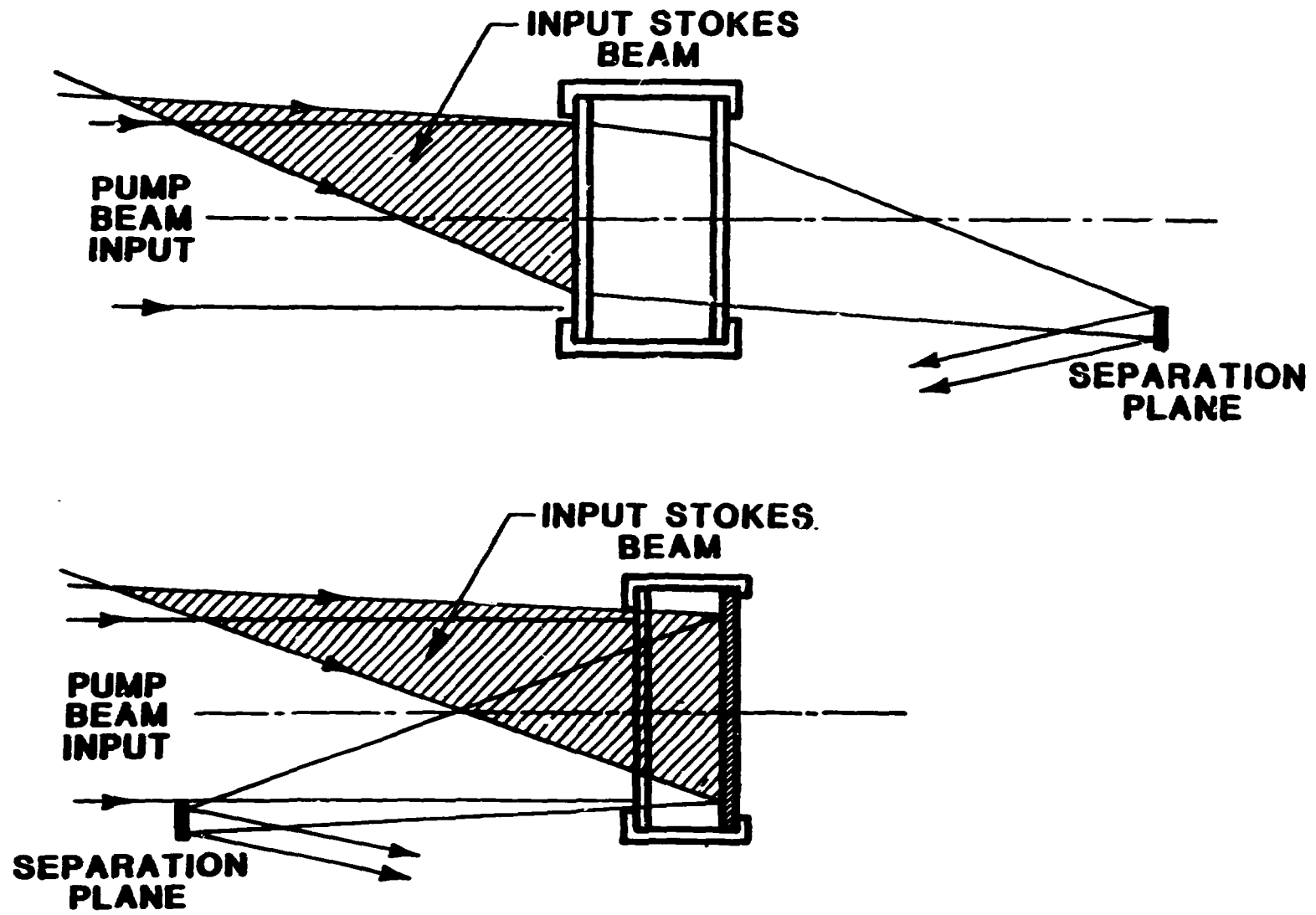

FIG 1

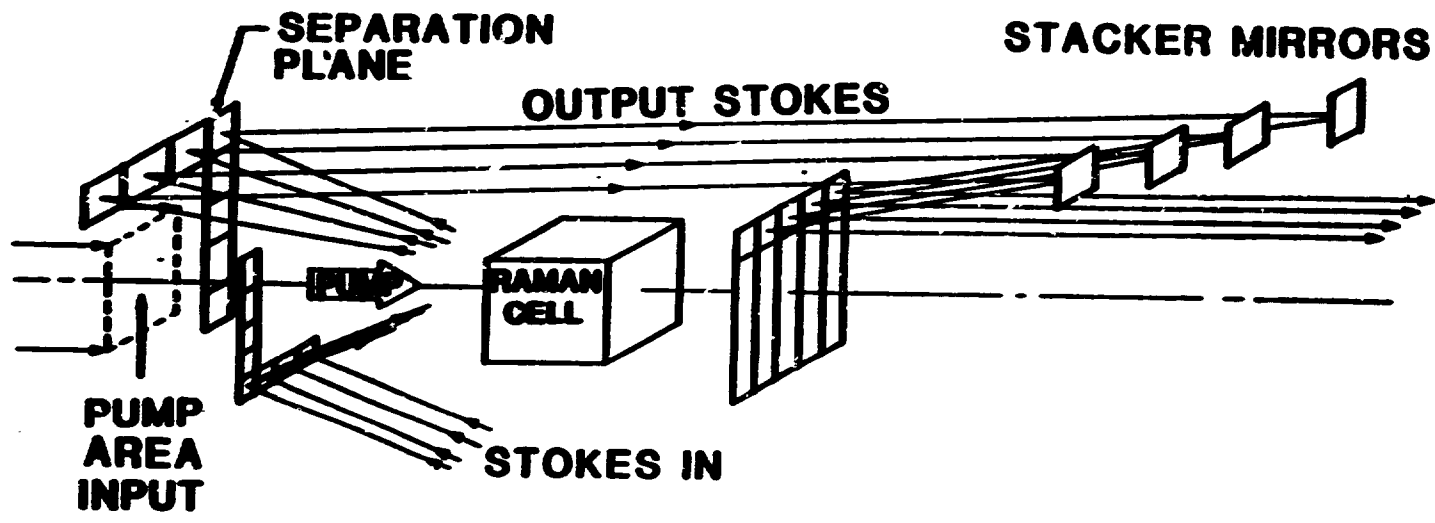
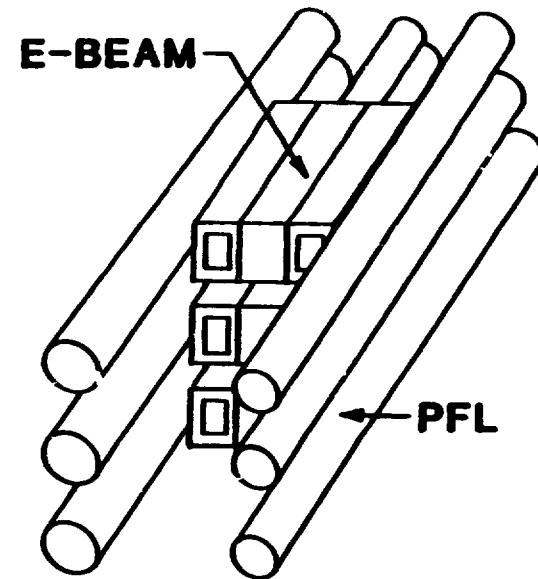
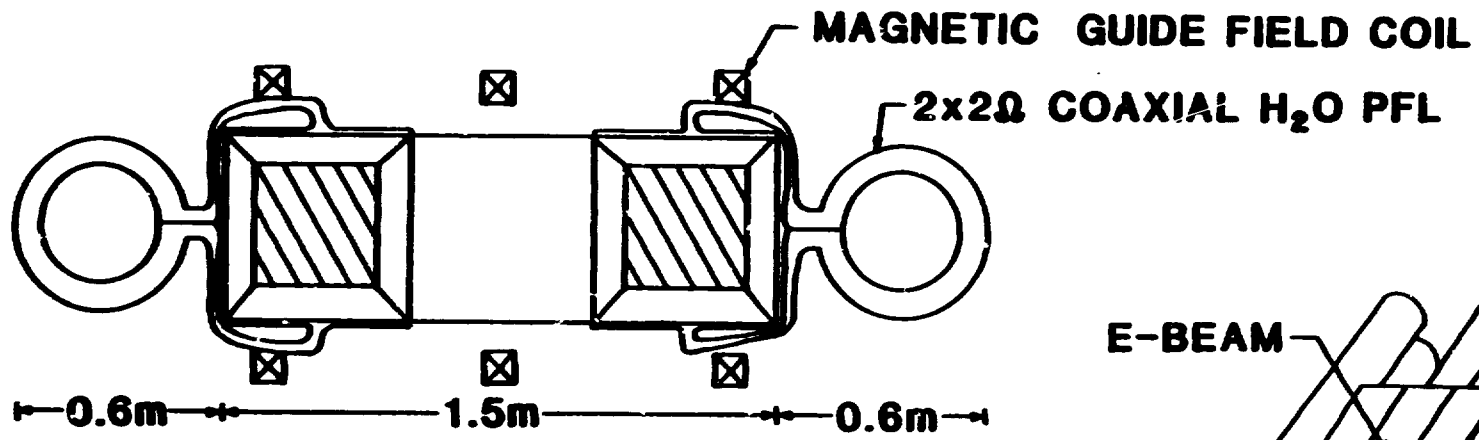

Fig 2

Fig 3



6 APERTURE UNIT

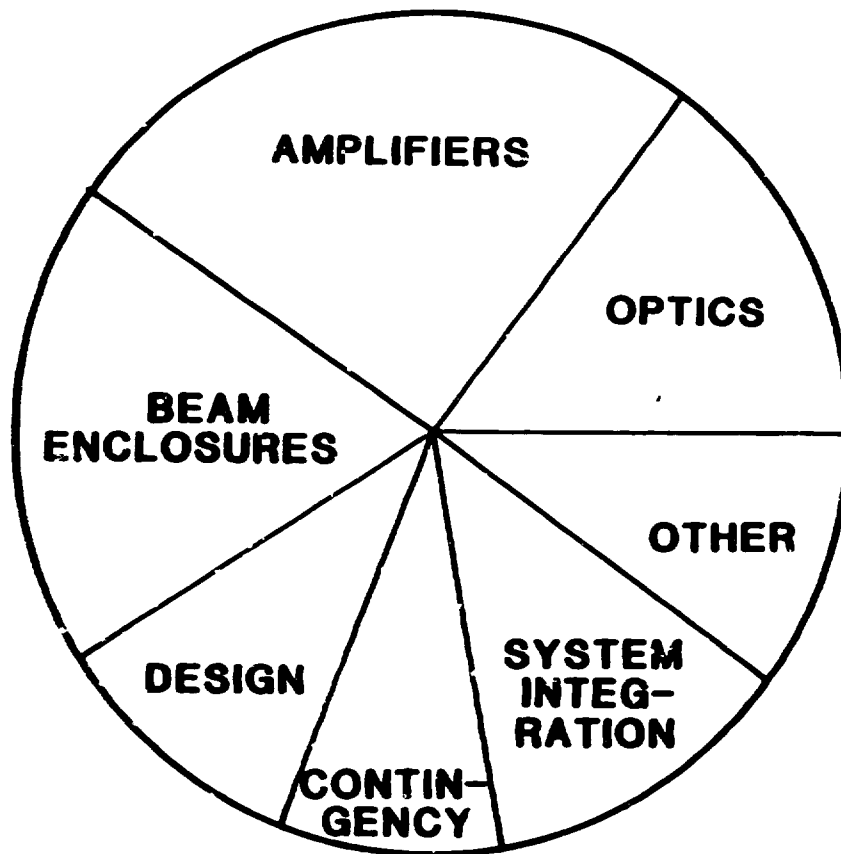

Fig 4

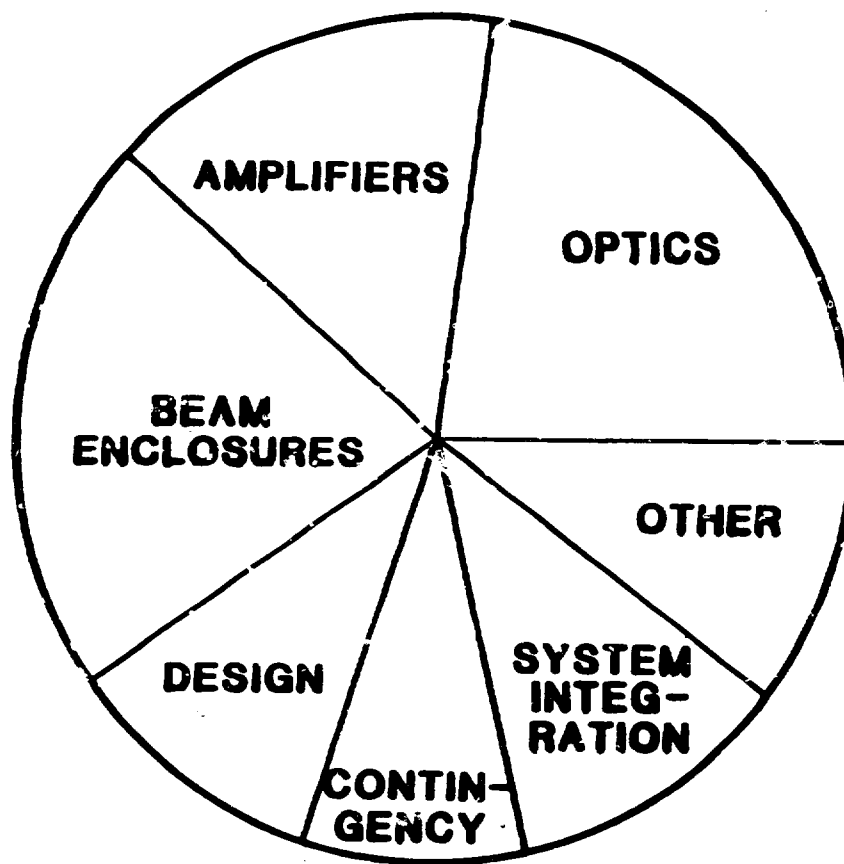

Fig 5

TABLE I
PULSE POWER REQUIREMENTS FOR KrF E-BEAM
SUSTAINED DISCHARGE LASER

	<u>Discharge</u>	<u>E-Beam</u>
Voltage (kV):	200	500
Current Density (A/cm ²):	60	3
Total Current (kA):	200	15
Impedance (Ω)	1	30
Pulse Duration (.nsec):	300	300
Energy (kJ)	12	2.5
Inductance (nH):	75	
Aperture (cm):	35 x 35	35 x 100
Length (cm):	100	

D. P. [unclear]
D. P. [unclear]†
R. G. [unclear]†
R. R. [unclear]

J. M. Egedorff†
J. J. Ewing†
N. A. Kurnit
M. J. Kushner†

Los Alamos National Laboratory
Spectra Technology, Inc.

11th Symposium on Fusion Engineering and

19-22 November 1985

GOALS

• K-5 laser systems
efficiency that are
acceptable cost
reduced size and

28

1960

THE REQUIREMENTS FOR A COMMERCIAL
DEuterium INERTIAL-FUSION DRIVER INCL

now

target

releas

se e

and

EXPENSIVE AND/OR INEFFICIENT DRIVERS CAN ADD SIGNIFICANTLY TO THE COST OF ELECTRIC POWER GENERATION

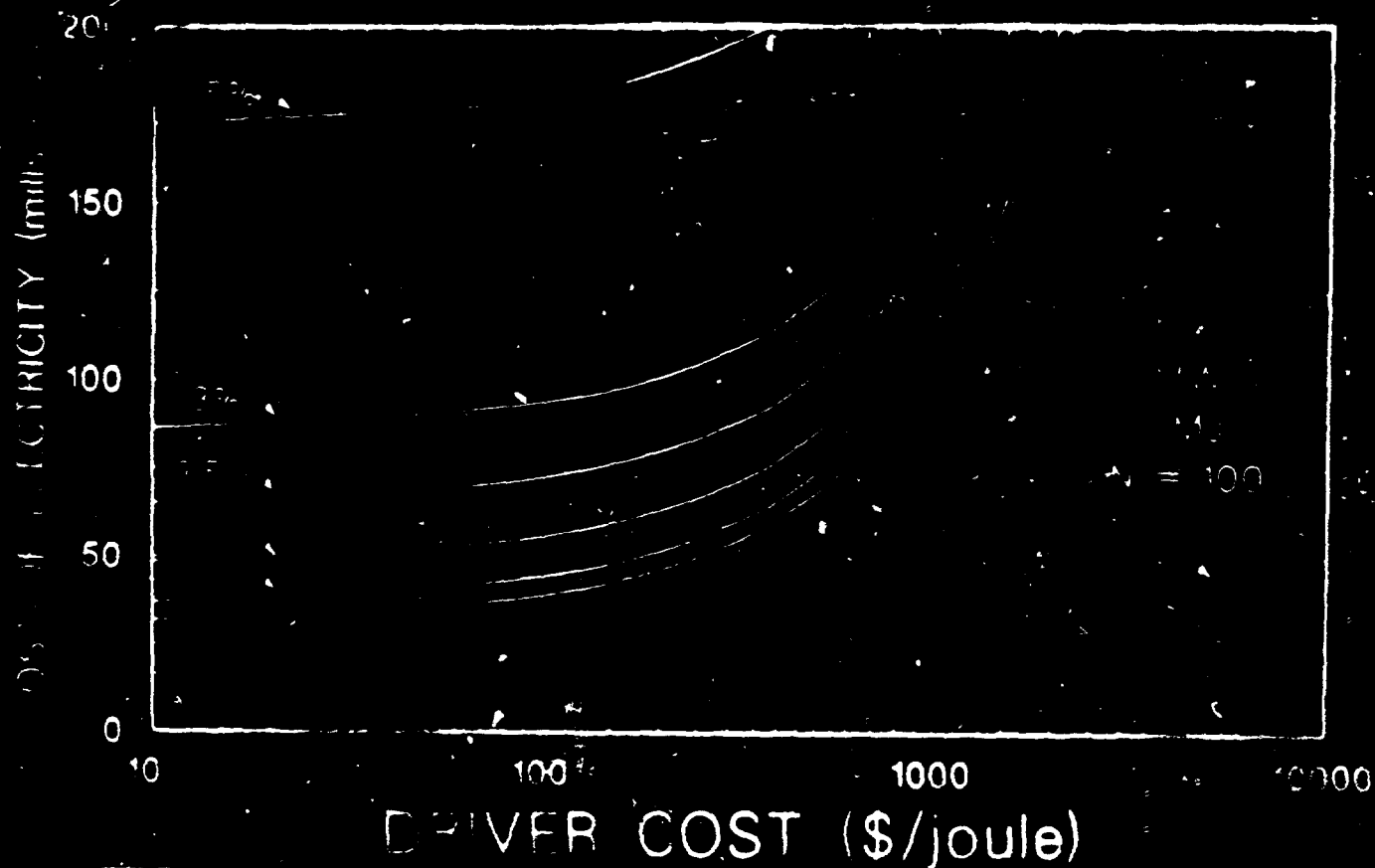

ORNL
Technology

Los Alamos

ACHES FOR KRF FUSION DRIVER R
AT LOS ALAMOS

ACH: Large e-beam
multiplexing

DL APP

FOR TWO APPROACHES
APPROACH

...ence
...ason
...de
...work
...be pl...

TRADE-OFFS FOR THE TWO APPROACHES: ADVANCED SYSTEMS

- * High gain system
- * Converts many low-quality beams into fewer high-quality short-pulse beams
- * Some optics, ...
- * High gain system with medium isolation
- * Factor, mass, ...

THE 5-MJ BASELINE DESIGN USES COST AND TECHNOLOGY FOR A SINGLE-PULSE FACILITY

25 main amplifiers

4 J/cm² optical fluence

8-ns beamlets

Amplifier dimensions 2.0 m x 3 x 2.8 m

System cost = \$500 million

Laser efficiency = 9.1%*

* "plug" to energy delivered to target

Los Alamos

TYPICAL RAMAN SUBSYSTEM SIZE

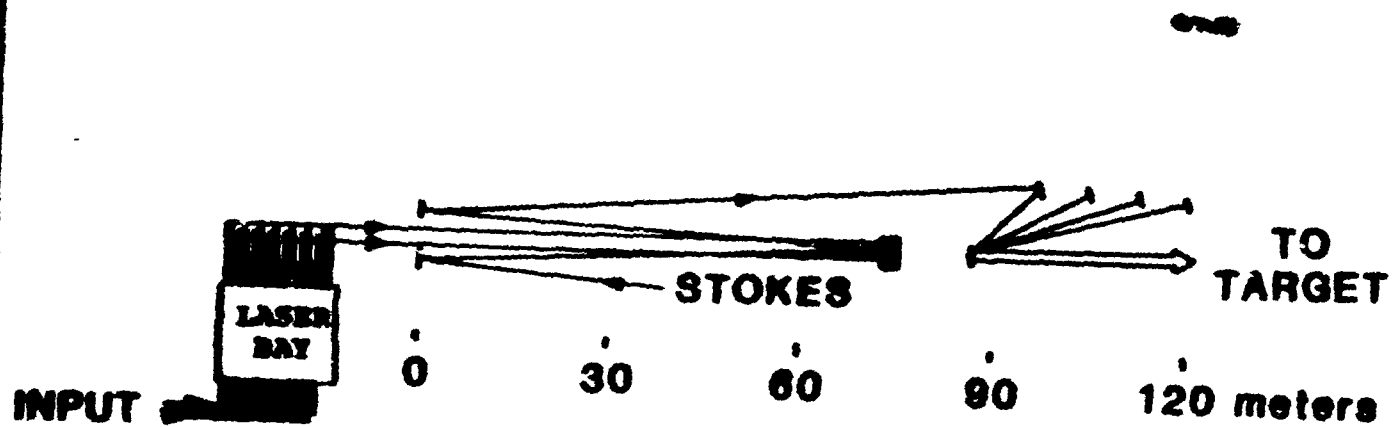

Spectra
Technology

Los Alamos

BASIC GEOMETRY ANALOGOUS TO PURE ANGULAR MULTIPLEXED K_rF AMPLIFIER

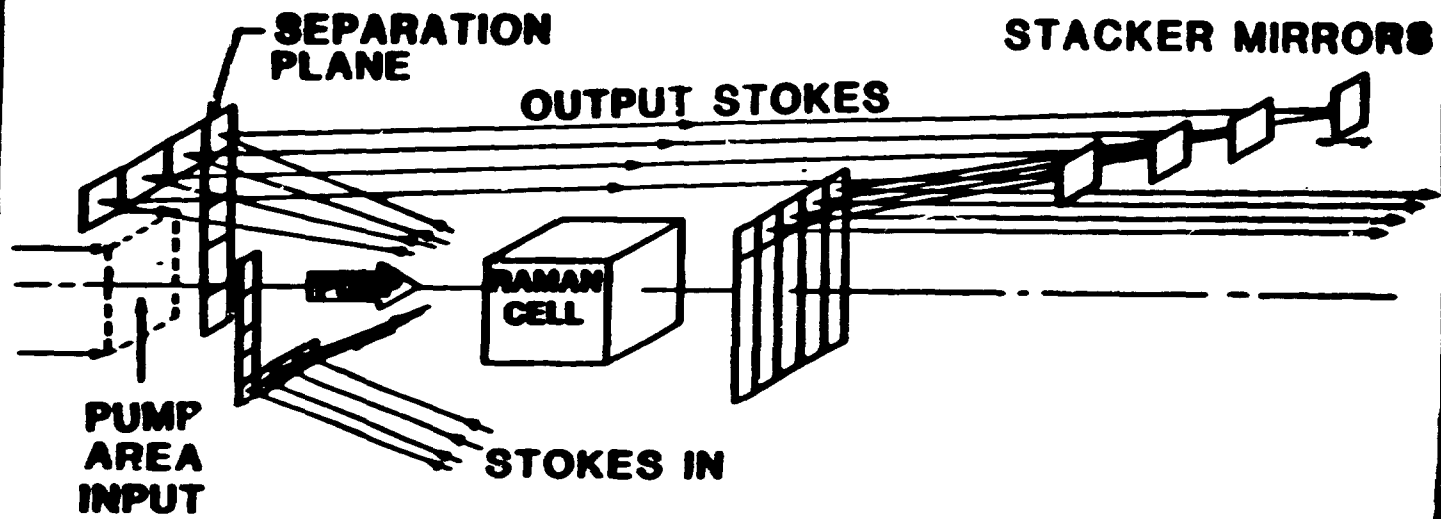

**Spectra
Technology**

Los Alamos

RAMAN CELL OPTICS

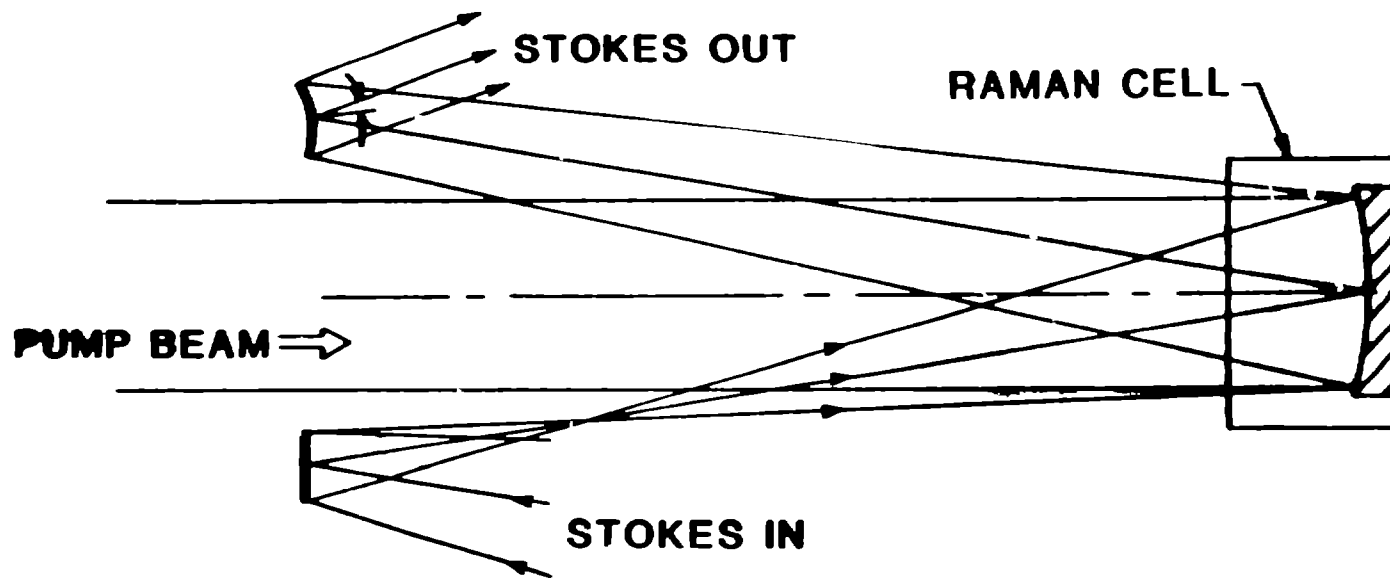

**Spectra
Technology**

Los Alamos

TWO-APERTURE K_rF DISCHARGE MODULE

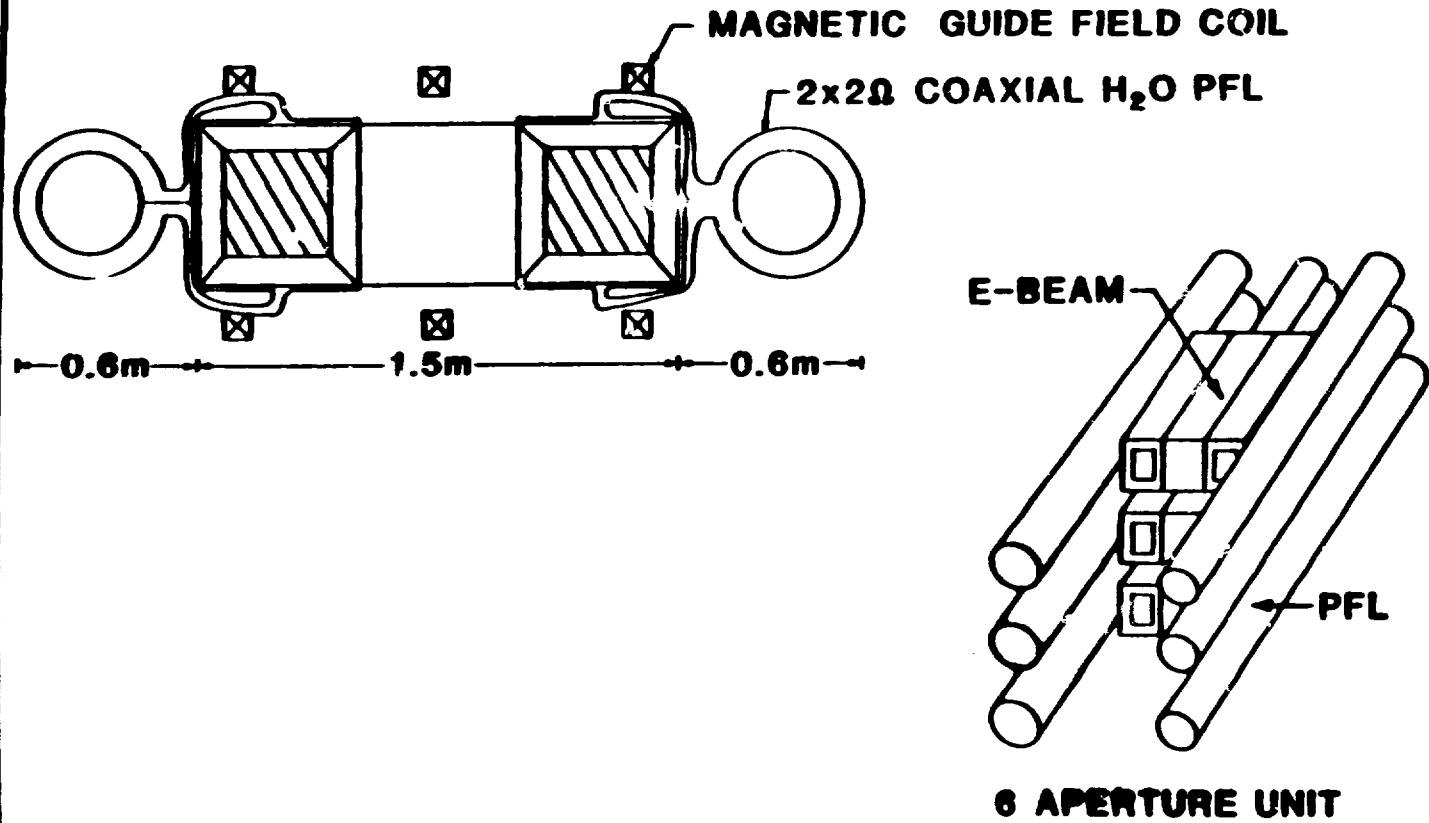

**Spectra
Technology**

Los Alamos

CHARGE/RAMAN AND EFFICIENCY IN BASELINE CASE

filters

fluence

amplifiers

\$14 joule

\$700 million

efficiency = 12.3%*

energy delivered to target

Los Alamos

AND EFFICIENCY HAS A LOWER COST OF ELECTRICITY



Spectra
Technology

Los Alamos

CONCLUSION

COMPARISON OF THE TWO
SYSTEMS INDICATES:

attractive

system is

SAFE